



D-311
D-313
INTERNAL



inside door



D-311 - D-313 INTERNAL

Printable curtain



Dynaco was founded in 1987, dedicated to finding a solution for any damages caused by - and to - high-speed roll-up doors. Inspired by flexible pool covers, Dynaco designed the first ever flexible, self-repairing door, known as the Dynaco Classic.

Later, another innovation followed: Dynaco's revolutionary Push-Pull technology, marketed as the "magic" door. Thanks to this continuous innovative approach and passion, Dynaco is known for producing "the most copied door in the world".

The company distributes doors through a network of professionals only, active in 5 continents.

With its most extensive product range in the industry, Dynaco stays always AHEAD. And always operates with the end-user in mind.

Both Dynaco D-311 LF and D-313 LF were designed for internal applications without specific production process related requirements.

Reintroduction block^{PT}



Motor incorporated in the drum - DVDM^{PT}

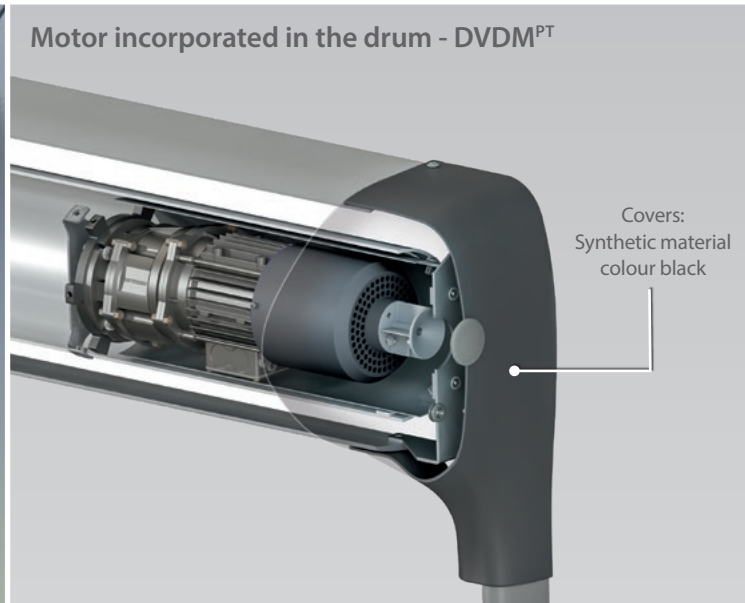

Low friction side guide

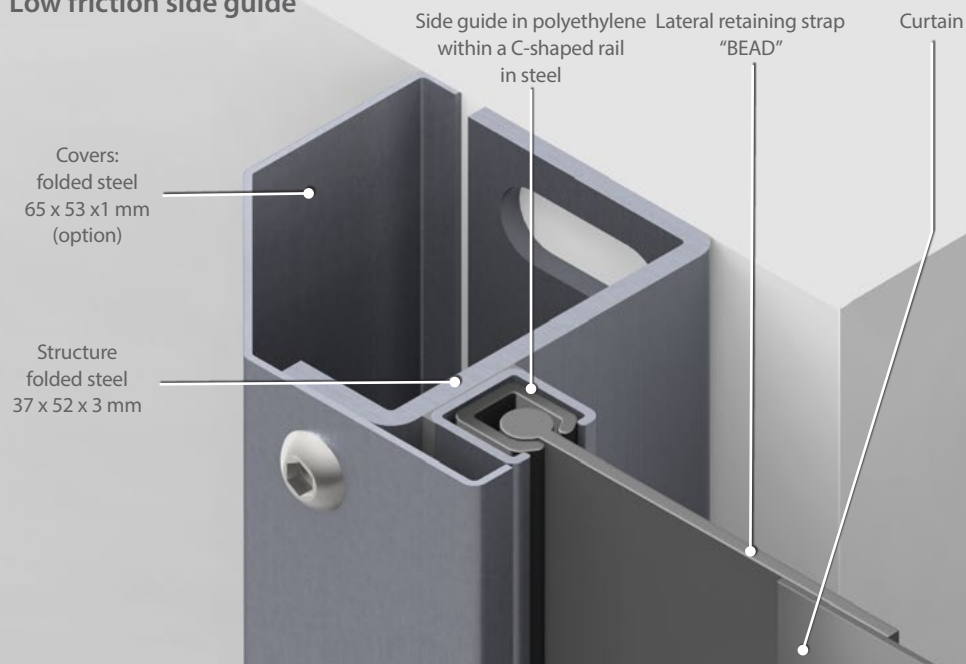

Both models protect your environment against drafts, humidity, dust and dirt, without requiring a lot of space.

Both its operating speed and superior sealing properties improve your traffic flows, while providing employee comfort, environmental control and energy savings.

In addition, the Dynaco D-313 LF is the slimmest high-speed door in the market.

Patented «LF» (Low Friction) technology, combined with a frequency inverter driven motor, ensures smooth operation.

Why this is the right door for your business?



Energy-saving

All Dynaco high-performance doors are designed to deliver the best possible sealing properties and minimal opening/closing cycle. Their dynamic barrier significantly reduce energy costs.



Extremely safe

At Dynaco we never compromise on safety. All doors operate according to the highest safety standards, thanks to their soft bottom edge and our self-testing safety devices.



Uninterrupted workflow

Our high-performance doors are designed to guarantee continuous operation, no matter the traffic conditions.



Reduced maintenance cost

With technical features such as our self-reinserting system, soft bottom edge and our frequency converter technology, Dynaco doors help you keep maintenance at a minimum.



Environment control

Dynaco doors not only open but also close fast. Their opening time is minimal to avoid temperature fluctuations that may affect product quality.



Comfort of use

Dynaco doors are suited to a wide range of applications. Thanks to our different opening options and certified safety-devices, you are safe whenever you cross a Dynaco door.



Perfect seal

Dynaco doors deliver significant energy savings, thanks to their patented side guides with «BEAD» technology. As production areas require the absence of dust, dirt and vermin, Dynaco doors offer a tight seal and high speed, which keep out any type of contaminant.



Smooth operation

The absence of curtain slats reduces building vibrations. Specially designed retaining straps run smoothly in the side guides, thus reducing any operating noise, which greatly contributes to user comfort.

Why Dynaco?



Automatic self-reinsertion

At Dynaco we invented the crash-forgiving, self-reinserting door. The one and only original. Its curtain automatically reinserts when dislodged, without intervention. This means: no repair costs, nor costly production downtime.

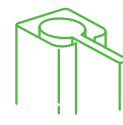

Patented BEAD side guides

Our patented BEAD side guides deliver the highest sealing properties, the best way to maintain environmental conditions and reduce energy costs. The Low Friction (LF) system allows not only for smooth and silent operation, but also increased safety, thanks to the absence of weight in the soft-bottom edge on every door.



Frequency converter

Dynaco doors operate with the most advanced drive unit in the industry. The combination of a frequency-driven motor and encoder offer smooth operation and reliability. Any wearable elements are reduced to a minimum.



Dynalogic control box

All doors can be fitted with a touch-screen control unit: our Dynalogic 5 control box. The most user-friendly, self-diagnostic option, which allows for remote control management. It increases efficiency and helps you monitor any door's status. At any time, from any desk.



Sleek, attractive design

Our doors' compact, sleek and minimalist design fits perfectly in any type of building architecture.



Certified performance

Performance of all Dynaco doors has been tested and certified by a third-party notifying body.



Dynaco offers a wide range of products for several industrial applications.
Find out more on www.dynacodoor.com.

D-311
D-313
INTERNAL

Always ahead



Dynaco Europe NV
Waverstraat 21 B-9310 Moorsel-Aalst (Belgium)
Tel. +32 53 72 98 98 info@dynacodoor.com
www.dynacodoor.com

About Dynaco

Dynaco is the world leader in high speed door technology. It offers state of the art solutions for both commercial and industrial applications, including sectional overhead doors.

Founded in 1987, Dynaco has acquired an extensive expertise in high performance doors. Yet it continues to invest in order to exceed your expectations of quality and performance. A network of certified and dedicated partners ensures an optimal service to customers all over Europe.

Dynaco is part of the ASSA ABLOY Group, the world leader in access solutions. Every day, we help billions of people experience a more open world.